

2320 SERIES RECUPERATIVE RADIANT TUBE BURNER, SUCTION TYPE

CAPABILITIES

- Quiet stable operation
- Uniform tube temperature
- Conversion of existing Bloom gas fired recuperative radiant tube burners to combination gas and oil firing easily accomplished
- Suitable for 5" (127 mm) and 7" (178 mm) and larger I.D. 'U' tubes or 'W' tubes and can be mounted on either leg of the tube

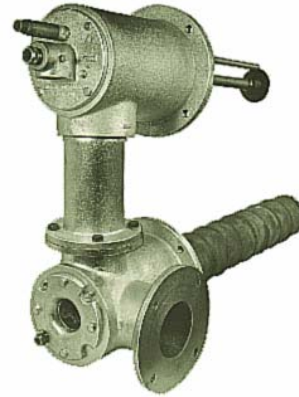

FEATURES

- Rugged construction
- Standard material suitable for exhaust gas temperatures up to 1400°F (760°C)
- Low NO_x air staged design available

CONTROL

- Gas fired burner may be operated with automatic control systems of the high-low modulating or tempered flame types
- Oil fired burners require on-off control systems

FLAME MONITORING

- U.V. Detector

APPLICATIONS

- Annealing Furnaces
- Galvanizing Furnaces
- Silicon Lines
- Wherever contact of the products of combustion with the material being heated is detrimental and where flame impingement is not allowed

BURNER IGNITION

- Manual Pilot (application dependent)
- Spark Ignited Pilot

FUEL CAPABILITIES

- Natural Gas
- Coke Gas
- Butane
- Propane
- #2 Fuel Oil

OPTIONS

- External insulation available or by others
- Right, left or straight exhaust connection
- Low NO_x designs
- Custom designs with lab development capabilities

CAUTION: The improper use of combustion equipment can result in a condition hazardous to people and property. Users are urged to comply with National Safety Standards and/or Insurance Underwriters recommendations

2320 SERIES RECUPERATIVE RADIANT TUBE BURNER, SUCTION TYPE

The 2320 Series Recuperative Radiant Tube Burner is suitable for operation with light distillate fuel oil or gaseous fuels having 500 BTU per cubic-foot or higher heating value.

Quiet stable operation and uniform tube temperatures are obtained by utilizing the patented Bloom Retention Nozzle. This nozzle distributes the air uniformly around the gas stream while creating a partial vacuum between the two streams and promoting stability.

A variety of ignition systems are available.

Each order or inquiry must specify the following:

1. Type of fuel and pressure
2. Maximum capacity required
3. Turndown required
4. Proposed method of control
5. Inside and outside diameter of tube
6. Tube length, configuration and distance between center of tube
7. Distance from burner flange to inside face of furnace wall
8. Proposed method of ignition
 - a. Manual pilot
 - b. Spark ignited pilot
9. Restrictions in tube

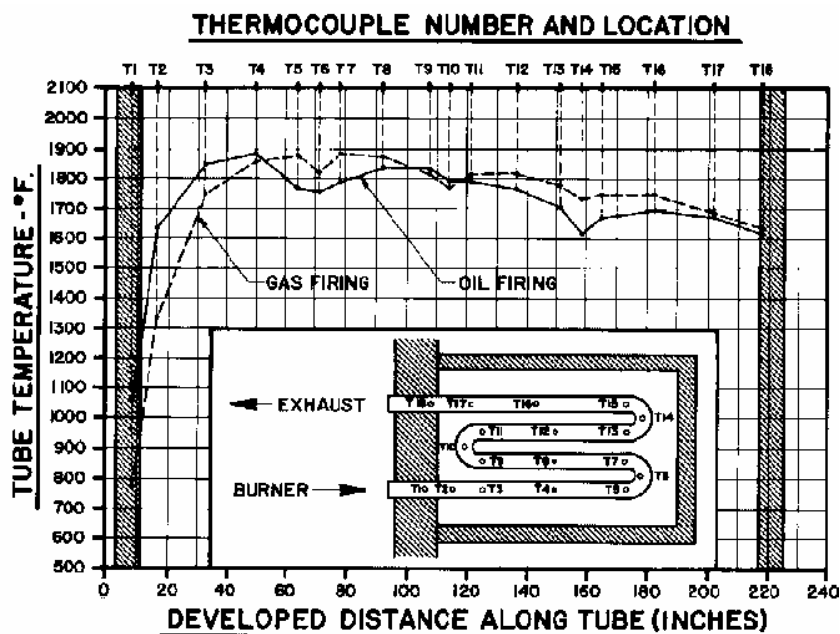

CAUTION: The improper use of combustion equipment can result in a condition hazardous to people and property. Users are urged to comply with National Safety Standards and/or Insurance Underwriters recommendations

2320 SERIES RECUPERATIVE RADIANT TUBE BURNER, SUCTION TYPE

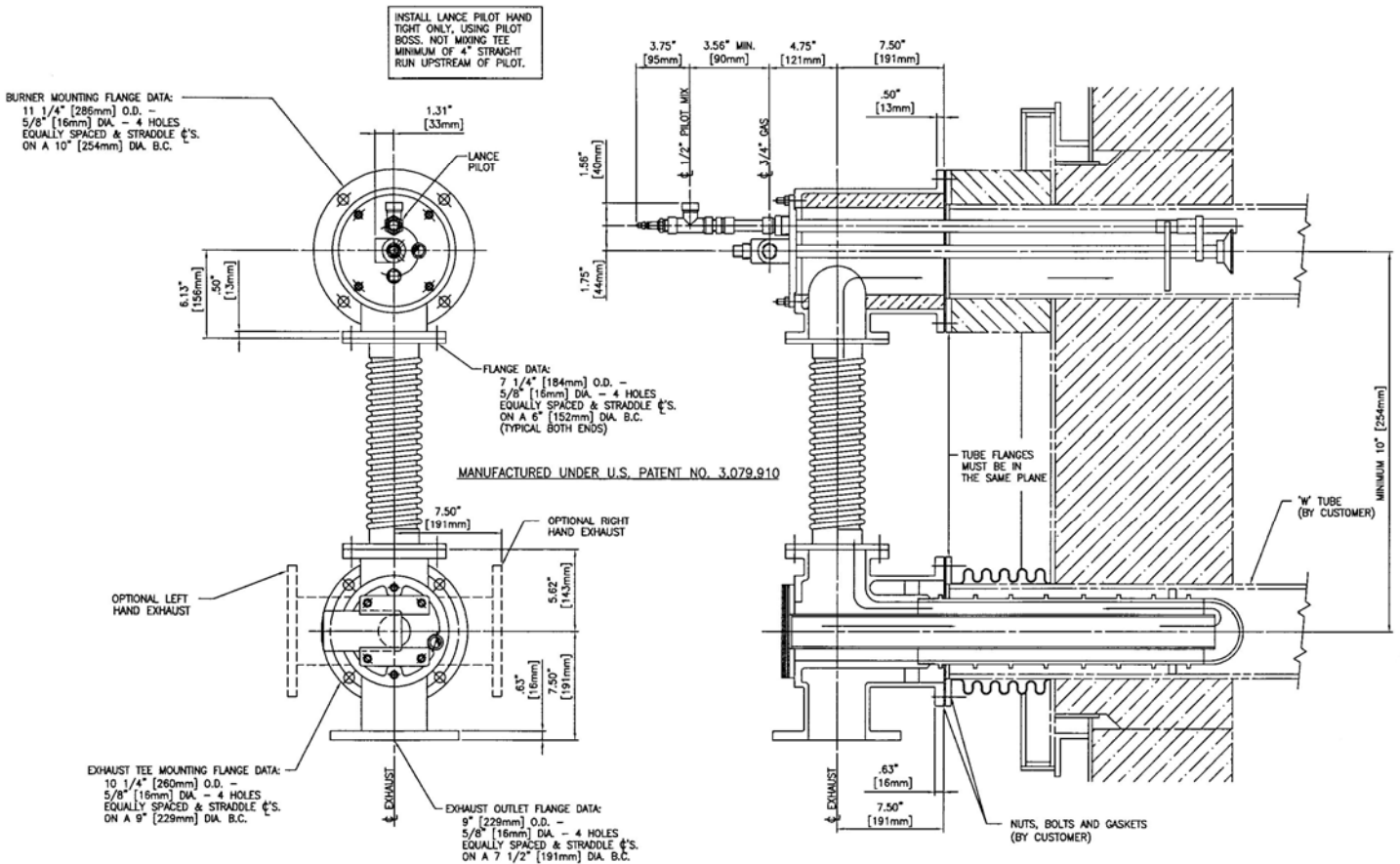

Catalog No. 2320 -	Tube I.D.	
	inches	mm
040	4	102
050	5	127
056	5 3/4	146
060	6	152

Designs available for other tube sizes.
 Please contact your Bloom representative.

NOTE: GENERAL DIMENSION INFORMATION. SEE BLOOM REPRESENTATIVE FOR CERTIFIED DIMENSIONS FOR CONSTRUCTION.

CAUTION: The improper use of combustion equipment can result in a condition hazardous to people and property. Users are urged to comply with National Safety Standards and/or Insurance Underwriters recommendations

2320 SERIES RECUPERATIVE RADIANT TUBE BURNER, SUCTION TYPE

PARTS LIST

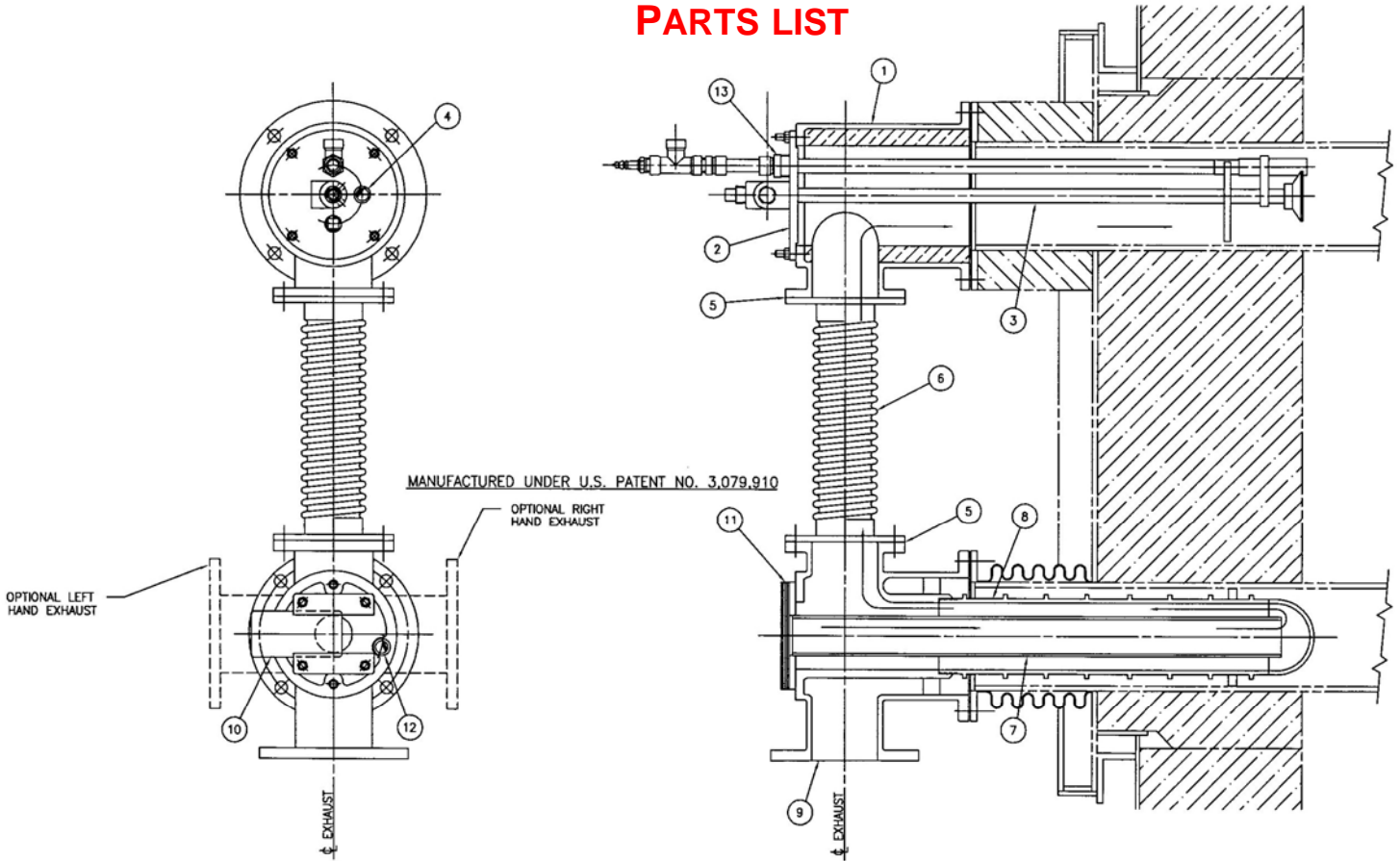

Part Number	Description
01	Burner Body
02	End Plate
03	Gas Nozzle Assembly
04	Observation Port
05	Wire Seal
06	Hot Air Tube
07	Cold Air Tube Assembly
08	Recuperator Assembly
*09	Exhaust Gas Tee
10	Orifice Plate
11	Gasket
12	Observation Port
13	Pilot Assembly

Part number must be preceded by catalog number.

Example:
To order Part 03 – Gas Nozzle Assembly for 2320-060 burner
Specify –
2320-060 – 03
(catalog number) (part number)

*Specify right or left hand exhaust
- gas tee (exhaust) – right hand shown

NOTE: GENERAL DIMENSION INFORMATION. SEE BLOOM REPRESENTATIVE FOR CERTIFIED DIMENSIONS FOR CONSTRUCTION

CAUTION: The improper use of combustion equipment can result in a condition hazardous to people and property. Users are urged to comply with National Safety Standards and/or Insurance Underwriters recommendations